

US-15~50

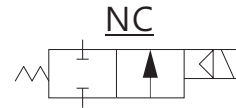
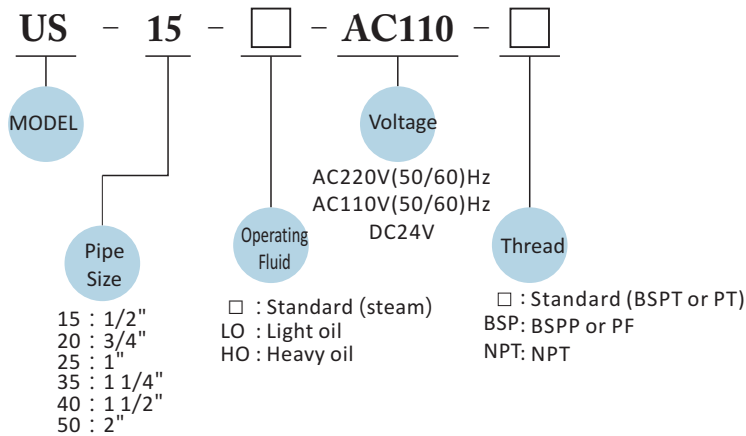

UD Series

PRODUCT DESCRIPTION

- US series is multiplex, piston guiding, conductive and normally closed (NC) 2/2 way solenoid valve.
- Applied fluid type : steam, heavy oil

CAUTIONS:

- Minimum pressure to open: over 0.5~1kgf-cm²
- Before pipelining, the pipe line must be very clean without any contaminants or impurity.
- To extend the lifetime, Y-line filter should be installed in the front end of solenoid valve.
- AC voltage tolerance: ± 10%; DC voltage tolerance: ± 1%
- It should be installed horizontally; vertical installation is not advisable.

Not Suitable For Fluid As Below:

- Liquid status when it is in high temperature; solid status when it is in low temperature.
- Corrosive fluid
- Viscosity over 20 cst

MATERIAL:

PARTS	Coil	Tube	Spring	Core	Plug	Piston	Piston plug	Valve body
MATERIAL	Special copper wire (H class)	Stainless steel	Stainless steel	Stainless steel	PTFE +15%GF	Brass	PTFE	Cast Bronze

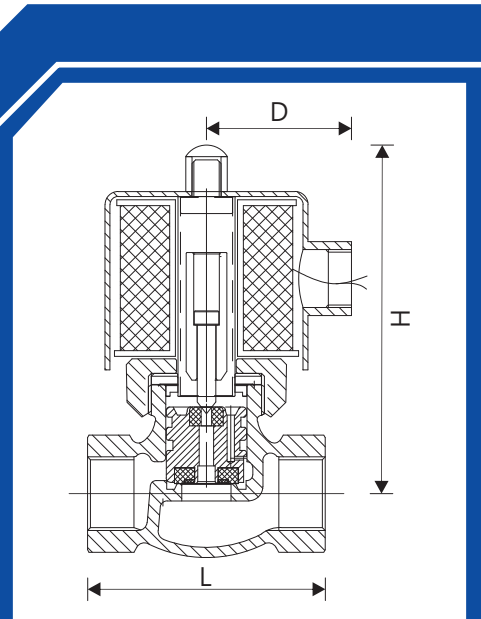

SPECIFICATION

MODEL	Waterproof DIN/flying lead Coil	NASS DIN Coil (IP65)	PIPE SIZE	CV	ORIFICE	FLUID TEMP. (°C)	Operating Pressure kgf / cm ² (bar)					Dimension (mm)			Weight (kg)
							Water	Air	Steam	Light oil	Gas	L	H	D	
US-15			1/2"	4.0	17mm	-5°C ~ +185°C			0.5~10	0.5~10		82	125	58	1.6
US-20			3/4"	6.0	17mm	-5°C ~ +185°C			0.5~10	0.5~10		82	125	58	1.67
US-25			1"	12	22mm	-5°C ~ +185°C			0.5~10	0.5~10		91	133	58	2.02
US-35			1 1/4"	18	30mm	-5°C ~ +185°C			1~10	1~10		111	141	58	3.08
US-40			1 1/2"	22	30mm	-5°C ~ +185°C			1~10	1~10		111	144	58	3.1
US-50			2"	48	50mm	-5°C ~ +185°C			1~10	1~10		163	175	58	6.82