



RE SERIES

Alphaair

EXTERNAL ADJUSTMENT



90° PNEUMATIC ACTUATORS

April 2016

ALPHAIR PNEUMATIC ACTUATORS EXTERNAL ADJUSTMENT New "RE" SERIES

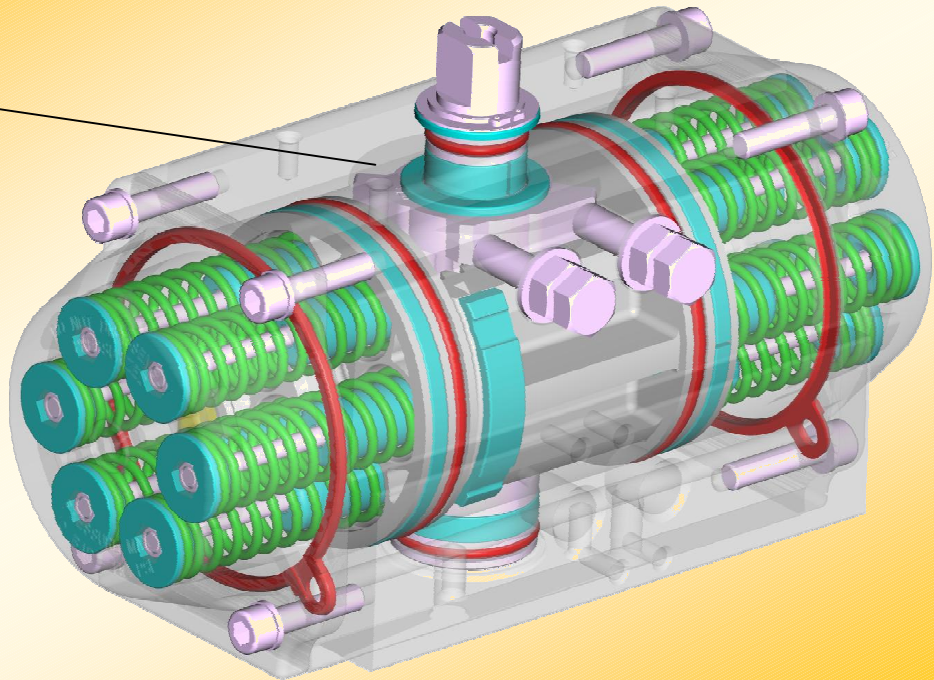
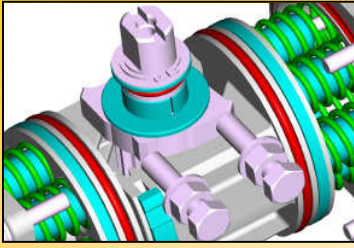

The new series of ALPHAIR Pneumatic Actuators with special "External Adjustment" system meets every quality and precision requirement.

The new "External Adjustment" system guarantees maximum precision on rotation adjusting, for normal and heavy conditions, in any application field.

Suitable for every requirement, ALPHAIR Pneumatic Actuators with special "External Adjustment" system are carefully designed for maximum torque rating and maximum lifetime.

More compact, heavy and reliable, ALPHAIR Pneumatic Actuators with special "External Adjustment" system can be easily assembled on every kind of valve.

STANDARD VERSION FEATURES

- **ASTM 6063 extruded Aluminium Body**, inside surface finishing Ra= 0,4-0,6. 25 µ Hard Anodizing.
- **EN AB 46100 die-cast Aluminium alloy Pistons**, 15 micron Anodizing.
- **EN AB 46100 die-cast Aluminium alloy Covers**, painted with 60-80 µ polyester powder.
- **Carbon steel Shaft**, 20 µ nickel-plated. Stainless Steel AISI 304 (A2) or AISI 316 (A4) as Optional.
- **External adjusting gear**, in Stainless Steel AISI 316 (A4).
- Screws in Stainless Steel AISI 304 (A2).
- Seals in nitrile nubber NBR.
- Optional HIGH Temperature = FPM/FKM. Optional LOW Temperature = SILICONE.
- Bearings in low friction LAT-LUB acetalic resin, easily replaceable for maintenance.
- Optional HIGH/LOW Temperature = PA 66. Optional VERY LOW Temperature = LEXAN.
- Pre-compressed Spring Cartridges, easily replaceable for maintenance, 25-30 micron polyester painted.
- Standard grease: High performances Syntetic Grease. Optional: special grease for HIGH/LOW Temperature.
- Several special protections available for chemical, pharmaceutical, food and industrial environments.
- Rotation adjustment +/-5° in both opening and closing position. Assembly precision +/-1°, made by electronic devices.
- Double lower drilling for valve fastening and centering, according to **ISO 5211-DIN 3337 Standards**.
- Double square lower female shaft key (starlike), according to **ISO 5211-DIN 3337 Standards** for assembly on valves with square key on line (0°) and diagonal key (45°).
- Solenoid connections according to **NAMUR VDI\VDE-3845 Standards**.
- Top drilling for accessories fastening, and upper shaft end according to **NAMUR VDI\VDE-3845 Standards**.
- Position indicator on request, enabling switch-box assembly on top.
- Aluminium adhesive nameplates, with progressive serial number punched.
- Lubrication carried out by the manufacturer, guaranteed for min. 1.000.000 operations.
- Running test and 100% seal test carried out with electronic equipment and certification of every individual product.
- Standard execution for temperatures from -20°C to +80°C (optional, special execution for extreme temperatures).
- Conformity for use in explosive environment; Ex II 2 GD "c" protection type.
- According to EN 15714-3 design and manufacture standard requirements.

AIR SUPPLY	TEMPERATURE RANGE	FEEDING PRESSURE	ROTATION ADJUSTING
Dry or lubricated filtered compressed air.	Standard -20° +80°C (-4 +175°F) HIGH Temperature -20° +150°C (-4 +300°F) LOW Temperature -40° +80°C (-40 +175°F) VERY LOW Temperature -60° +80°C (-76 +175°F)	8 bar/120 psi – CONTINUOUS 10 bar/142 psi - MAXIMUM	+/- 5°

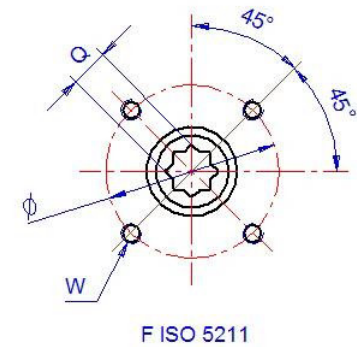
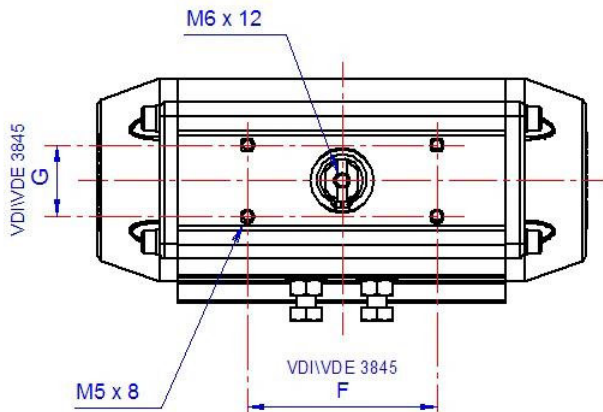
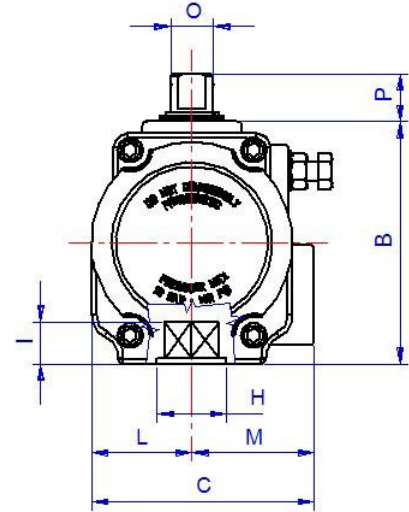
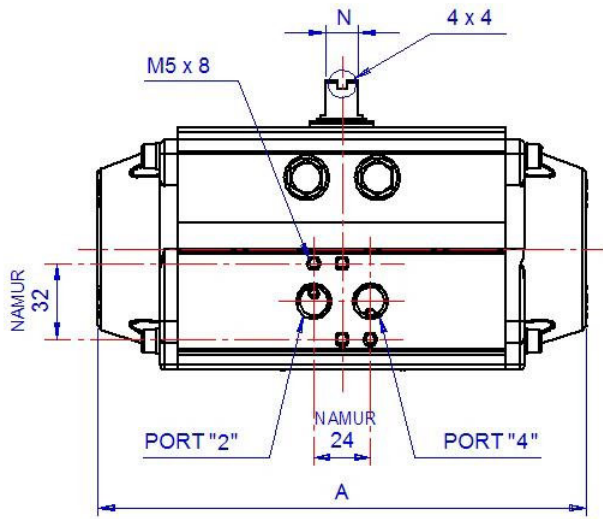

POSITION	TYPE															
	RE 043	RE 051	RE 064	RE 076	RE 086	RE 101	RE 116	RE 126	RE 146	RE 161	RE 181	RE 201	RE 241	RE 271	RE 331	RE 421
A-90°	140	138	155	203	239	257	304	335	398	424	482	527	604	685	850	934
B	62	69	85	102	112	127	145	157	177	196	220	248	298	332	414	534
C	63,5	75	86	94	104	120	134	150	164	182	201	222	300	352	400	521
VDI/VDE 3845 F x G	50 x 25	80 x 30					80 x 30 130 x 30		130 x 30							200 x 50
L	27	33,5	38	42,5	49	55	64	70	80	89	99	110	150	166	190	249
M	36,5	41,5	48	51,5	55	65	70	80	84	93	102	112	150	166	210	272
Port A Port B DIN 259	1/8" GAS-NPT			1/4" GAS-NPT								1/2" GAS-NPT				
N x O	8 x 12			14 x 18			27 x 36			32 x 42		32 x 60		55 x 80		
P	20					30			50					80		
Q x I	9 x 10 11 x 13	9 x 10 11 x 13	9 x 10 11 x 13 14 x 16	11 x 13 14 x 16 17 x 20	14 x 16 17 x 20	14 x 16 17 x 20	17 x 20 22 x 25	17 x 20 22 x 25 27 x 29	22 x 25 27 x 29	22 x 25 27 x 29	*27 x 29 36 x 39	27 x 29 36 x 39	*36 x 39 46 x 50	*36 x 39 46 x 50	*46 x 50 55 x 60	*55 x 60 75 x 80
F ISO 5211	F04	F04	F05/07	F05/07	F05/07	F07/10	F07/10	F07/10	F10/12	F10/12	F10/12	F14	F14	F16	F16/25	F25/30
Optional	F03/05	F03/05	F3/5/7 F04			F5/7/10		F7/10/12			F14	F10/12	F12/16 F16	F12/16 F14		F(16) /25/30

POSITION	F ISO 5211											
	F03	F04	F03/05	F05	F05/07	F5/7/10	F07/10	F10/12	F14	F16	F25	F30
Ø (W)	Ø 36 (M5x8)	Ø 42 (M5x8)	Ø 36 (M5x8) Ø 50 (M6x9)	Ø 50 (M6x9)	Ø 50 (M6x9) Ø 70 (M8x12)	Ø 50 (M6x9) Ø 70 (M8x12) Ø 102 (M10x15)	Ø 70 (M8x12) Ø 102 (M10x15)	Ø 102 (M10x15) Ø 125 (M12x18)	Ø 140 (M16x24)	Ø 165 (M20x30)	Ø 254 (M16x24) N°8 FORI	Ø 298 (M20x35) N°8 FORI
H	25	30	25	35	35 (RE 086=40)	40	55	85 (RE 161=75)	100	130	200	200

CONSTRUCTION PARTS - SPECIFICATIONS

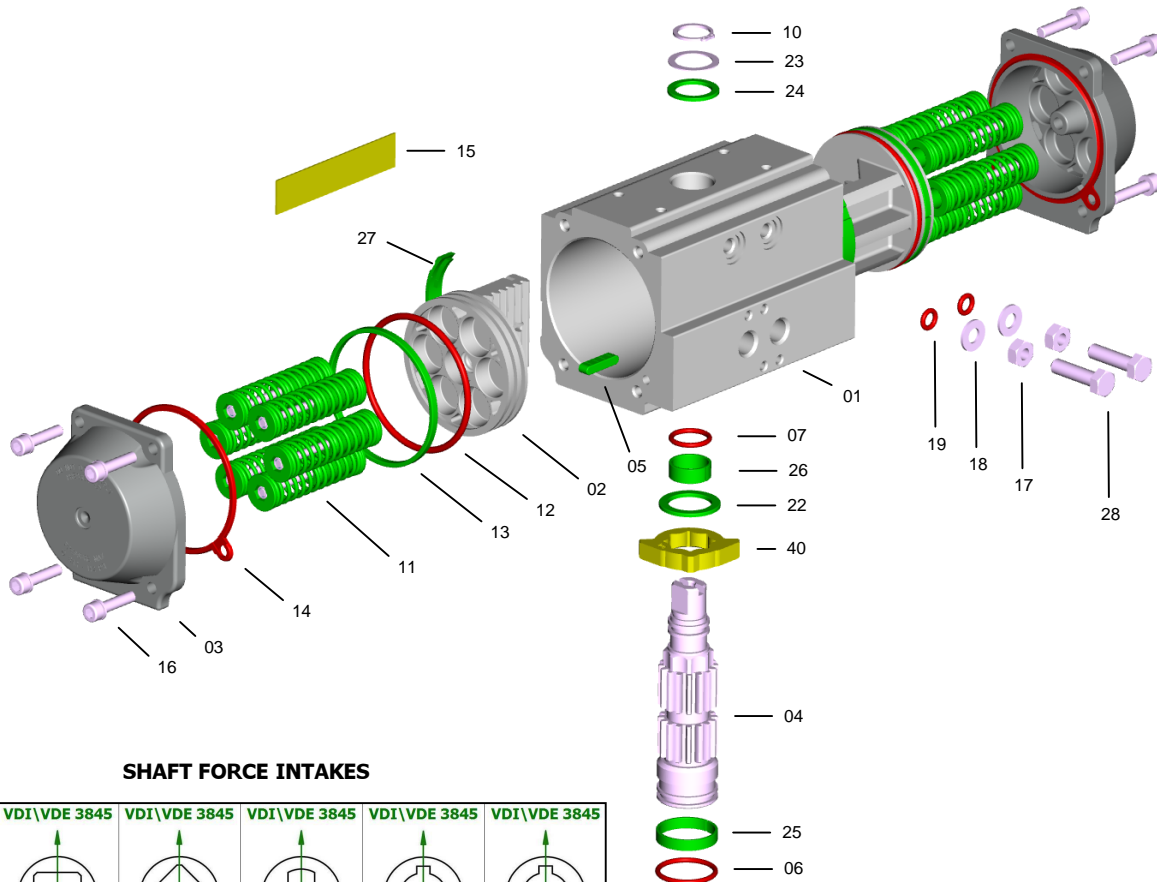

SHAFT FORCE INTAKES

VDI\ VDE 3845	VDI\ VDE 3845	VDI\ VDE 3845	VDI\ VDE 3845	VDI\ VDE 3845	VDI\ VDE 3845
STANDARD ALPHAIR S = L\D	L	D	H	V	W

PART	QUANTITY	DESCRIPTION	MATERIAL	SPECIFICATION	PROTECTION
1	1	Body	Extruded aluminium alloy	EN AW 6063 T6	A - N - TF
2	2	Piston	Aluminium alloy	EN AB 46100 T6	A
3	2	Cover	Aluminium alloy	EN AB 46100 T6	N - V - TF
4	1	Shaft	Carbon steel optional S.S. AISI 304 (A2) optional S.S. AISI 316 (A4)	ASTM A105	N
5 *	2	Antiejection key	Acetalic resin - PA66 - PA66 - LEXAN		
6 *	1	Lower shaft O-Ring	NBR - FPM\FKM - Silicone		
7 *	1	Upper shaft O-Ring	NBR - FPM\FKM - Silicone		
10 *	1	Seeger ring	Carbon steel		N
11	0-12	Spring cartridge	Carbon steel, PA 66, S.S.	C-98	V
12 *	2	Piston O-Ring	NBR - FPM\FKM - Silicone		
13 *	2	Piston head bearing	Acetalic resin - PA66 - PA66 - LEXAN		
14 *	2	Cover gasket	NBR - FPM\FKM - Silicone		
15	1	Nameplate	Aluminium		
16	4+4	Cover fastening screw	Stainless Steel	AISI 304 (A2)	
17	2	Nut	Stainless Steel	AISI 304 (A2)	
18	2	Washer	Stainless Steel	AISI 304 (A2)	
19 *	2	O-Ring	NBR - FPM\FKM - Silicone		
22 *	1	Gear antifriction washer	Acetalic resin - PA66 - PA66 - LEXAN		
23 *	1	Shaft thrust washer	Stainless Steel	AISI 304 (A2)	
24 *	1	Shaft antifriction washer	Acetalic resin - PA66 - PA66 - LEXAN		
25 *	1	Lower shaft pilot ring	Acetalic resin - PA66 - PA66 - LEXAN		
26 *	1	Upper shaft pilot ring	Acetalic resin - PA66 - PA66 - LEXAN		
27 *	2	Piston bearing	Acetalic resin - PA66 - PA66 - LEXAN		
28	2	Adjusting gear screw	Stainless Steel	AISI 304 (A2)	
40	1	Adjusting gear	Stainless Steel	AISI 316 (A4)	

* SPARE PARTS SET: Standard, Special HIGH Temperatures, Special LOW Temperatures, Special EXTRA LOW Temperatures

Protections

A = Anodizing N = chemical Nickel-plating V = Painting TF = Anodizing+PTFE

COATINGS – MATERIAL TREATMENTS

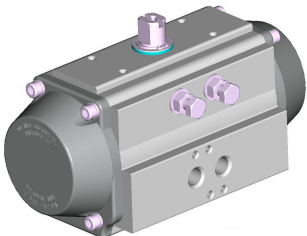
	AV	DESCRIPTION				USED FOR
		Body	Covers	Pistons	Shaft	
	standard	Anodizing	Polyester painting	Anodizing	High phosphorous nickel-plating (12%) opt. AISI 304 (A2) opt. AISI 316 (A4)	- Industry, general use.
	Colour	Grey	Grey	Brown	Polished steel	
Thickness	25 µ	60/80 µ	15 µ	20 µ		

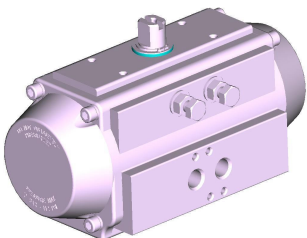
	NN	DESCRIPTION				USED FOR
		Body	Covers	Pistons	Shaft	
	standard	High phosphorous nickel-plating (12%)	High phosphorous nickel-plating (12%)	Anodizing	High phosphorous nickel-plating (12%) opt. AISI 304 (A2) opt. AISI 316 (A4)	- Industry, general use. - Caustic soda. - Detergents. - Low alkaline solutions.
	Colour	Polished steel	Polished steel	Brown	Polished steel	
Thickness	20 µ	20 µ	15 µ	20 µ		

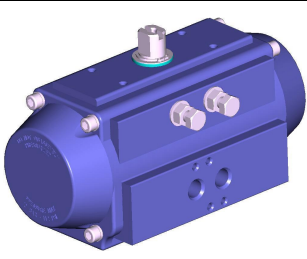
	TF TF	DESCRIPTION				USED FOR
		Body	Covers	Pistons	Shaft	
	standard	Anodizing + PTFE coating	Anodizing + PTFE coating	Anodizing	High phosphorous nickel-plating (12%) opt. AISI 304 (A2) opt. AISI 316 (A4)	- Industry, general use. - Low alkaline and low acid solutions. - Marine environments. - High temperatures.
	Colour	Blue	Blue	Brown	Polished steel	
Thickness	Anodizing 25 µ PTFE 15 µ	Anodizing 15 µ PTFE 15 µ	15 µ	20 µ		

ANODIZING

Anodizing is an electrolytic process that produces anodic coating on aluminum, called alumine, with high thickness. Alumine is one of the most hard known materials, with resistance values up to 400-600 HV (45-65 HRC); properties and features of Anodizing (alumine thickness 25 micron) are well know and appreciated both for mechanical and chemical resistance.

- **Best friction and corrosion resistance, best surface hardness, good thermic and electrical insulation.**

ELECTROLESS NICKEL-PLATING

Chemical nickel-plating is an electroless coating process that gives nickel layers at extremely constant thickness also on sharp angles, blind-holes, threads and grooves recess. During the process, nickel is combined with phosphor at a percentage of 12% (high-phosphor). The obtained surface hardness is about 400-480 HV (45-55 HRC).

- **Best friction and corrosion resistance, best surface hardness, best external appearance similar to S.S., increased resistance to alcali and detergents in sanitary and food applications.**

POLYESTER PAINTING

Polyester painting is obtained through powder coatings on polarized parts, by means of light differences in electrical potentials. After applications, parts are baked in order to polymerize and let the painting be spread to avoid micro-porosity. The best elasticity can be obtained at 60/80 micron thickness; a satisfactory adhesion can be assured by sandblasting or brushing, and by special degreasing baths of the rough pieces to be treated.

- **Better corrosion resistance, protection against crashes, better external appearance and several available colours, resistance to chemicals.**

ANODIZING + PTFE COATING

As further improvement of the hard anodising treatment on aluminium alloys, protective coatings made of PTFE are used; this material is known for its particular chemical and physical features. On these double treated surfaces, oxide hardness and low roughness (internal slipping parts) is summed to the chemical resistance and the excellent qualities as a thermic barrier of PTFE (external surface, subject to corrosion).

- **Better corrosion resistance, protection against high temperatures and crashes, extreme resistance to chemicals and in marine environments.**

AISI 304 (A2) OR AISI 316 (A4) STAINLESS STEEL SHAFT - OPTIONAL

AISI 304 (A2) and AISI 316 (A4) Stainless Steel shafts, with their great corrosion resistance, are recommended for special applications such as: marine and chemical environments, food and pharmaceutical industry, high temperature applications.



Via Molino Emili, 16 - 25030 MACLODIO (BS) Italy - Tel. +39 030 97 86 61/2- Fax +39 030 97 86 63
www.alphair.it - www.alphapompe.it

All rights reserved - Not guaranteed for accuracy - Data subject to change without notice - Older data sheets are invalid

COMPANY WITH
QUALITY SYSTEM
CERTIFIED BY DNV GL
= ISO 9001 =

