

Vickers®

Proportional Valves



Proportional Directional Valves with Feedback

K(B)SDG4V-3, 1* Series

Pressures to 350 bar (5075 psi)



This product has been designed and tested to meet specific standards outlined in the European Electromagnetic Compatibility Directive (EMC) 89/336/EEC, amended by 91/263/EEC, 92/31/EEC and 93/68/EEC, article 5. For instructions on installation requirements to achieve effective protection levels, see this leaflet and the Installation Wiring Practices for Vickers Electronic Products leaflet 2468. Wiring practices relevant to this Directive are indicated by  Electromagnetic Compatibility (EMC).

VICKERS

Introduction

General Description

These four-way solenoid operated proportional valves have a high dynamic performance which enables them to be used in closed-loop applications, previously possible only with servo valves. Various spool options are available for rated flows up to 40 L/min (10.6 USgpm). Working pressures are to 350 bar (5000 psi). The spool position is monitored by an LVDT which feeds back information to the amplifier, enabling spool position to be accurately maintained.

This valve type can be supplied with or without an integral amplifier built directly onto the valve.

KSDG4V-3

Without the integral amplifier.

Features and Benefits

- Wide range of spool and flow rate options.
- Supported by a broad range of amplifiers and auxiliary function modules.

- Electronic feedback LVDT ensures accurate spool position control.
- Internal current feedback provides optimal control.
- Vibration and shock tested.
- Full CE electromagnetic compatibility.

KBSDG4V-3

With integral control electronics.

Factory-set adjustments of gain, spool deadband compensation and offset ensure consistent repeatability valve-to-valve.

The only electrical inputs required are power supply (24V) and a voltage command signal of $\pm 10V$. The amplifier is housed in a robust metal enclosure, sealed against ingress of water and other fluids. Electrical connections are via a standard 7-pin plug.

A spool position monitor pin allows the function of the valve to be electrically monitored. Ramp functions, if required, can be generated externally.

Features and Benefits

- Factory-sealed adjustments ensure valve-to-valve reproducibility
- Installation wiring reduced and simplified.
- Standard 7-pin connector.
- Standard 24V DC supply with wide tolerance band.
- Standard $\pm 10 V$ DC command signals.
- Valve with integrated amplifier selected, ordered, delivered and installed as one performance-tested package.
- Spool position monitor pin to help with troubleshooting.
- Simple valve removal and replacement for service (plug & play).
- Vibration and shock tested.
- Auxiliary DIN rail mounted electronic function modules available.
- Full CE electromagnetic compatibility.
- IP67 valve, environmental protection rating.
- Optional valve enable function.

Contents

Introduction	2
Features and Benefits	2
Model Codes	3
Typical Section	4
Spool Symbols	4
Functional Symbols	4
Operating Data	5
Pressures and Flow Rates	6
Performance Curves	6
Installation Dimensions	8
Subplates and Mounting Surfaces	9
Electrical Information	10
Application Data	12

Model Codes

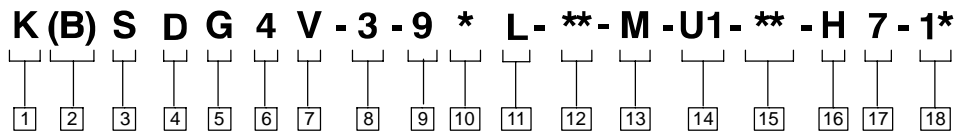

1 Valve type

K – Proportional valve

2 Integral amplifier

B – Integral amplifier “B” series
Omit for models without integrated amplifiers.

3 Feedback arrangement

S – Closed-loop

4 Control type

D - Directional valve

5 Mounting

G – Subplate mounted

6 Operation

4 – Solenoid operated

7 Pressure rating

V – >250 bar (3625 psi) on ports P, A, & B

8 Interface

3 – ISO 4401, size 03-02-0-94
ANSI/B93.7M-D03

9 Spool type (center condition)

9 – Zero lap (biased underlap)

10 Spool type, spring offset condition

2 – Ports P, A, & T blocked
6 – Port P blocked, A & B to tank

11 Valve build

L – Standard build

12 Rated flow at 70 bar (1000 psi) loop Δp pressure drop

05 – 5 L/min (1.3 USgpm)
12 – 12 L/min (3.2 USgpm)
24 – 24 L/min (6.3 USgpm)
40 – 40 L/min (10.6 USgpm)

For actual maximum flow refer to Power capacity envelope curves, page 7.

13 LVDT plug

(omit for valves with integral amplifier)
M – Standard LVDT (mating plug supplied)

14 Solenoid connector

(omit for valves with integral amplifier)
U1 – ISO 4400/DIN 43650, non-integral amplifier type only (mating plugs supplied)

15 Electrical connection (KBS valves only)

PC7 – 7 pin connector without plug
PE7 – 7 pin electrical plug with mating half
PH7 – As PE7 but with pin “C” used for enable signal
PR7 – As PC7 but with pin “C” used for enable signal

16 Coil rating

H – 24 VDC amplifier supply

17 Port T pressure limit code

7 – for all spools

18 Design number

1* series. Subject to change



Warning

Valves with integral amplifiers are supplied with or without the metal 7-pin plug. The Vickers plug, part no. 934939, must be correctly fitted to ensure that the EMC rating and IP67 rating are achieved. The plug retaining nut must be tightened with a torque of 2-2,0 Nm (1.5-2.5 lbf ft) to effect a proper seal.

Typical Section View

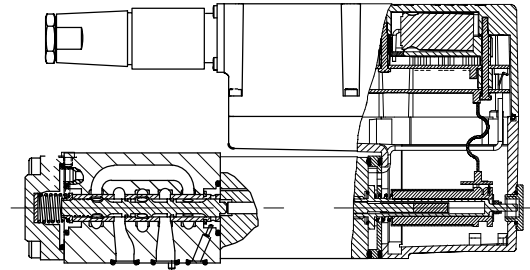

KBSDG4V-3

Spool Symbols

Available Spools for K(B)SDG4V-3

Spool Types and Flow Ratings

Symmetric Spools

Base line starting at $\Delta p = 5$ bar (75 psi) per metering flow path, e.g. B to T. For actual maximum flow refer to power capacity envelope curves.

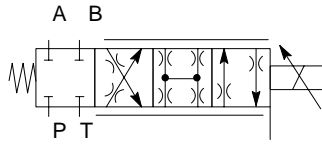

Spool type 92L

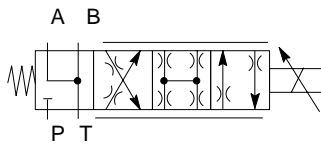

Spool type 96L

Spool code

Spool symbol

Flow rating

For K(B)SDG4V-3 valves:

92L05	92L	5 L/min (1.3 USgpm)
92L12	92L	12 L/min (3.2 USgpm)
92L24	92L	24 L/min (6.3 USgpm)
92L40	92L	40 L/min (10.6 USgpm)
96L05	96L	5 L/min (1.3 USgpm)
96L12	96L	12 L/min (3.2 USgpm)
96L24	96L	24 L/min (6.3 USgpm)
96L40	96L	40 L/min (10.6 USgpm)

Functional Symbols

Model Types KBSDG4V-3

proportional directional valve (with integral electronics)

Model Types KSDG4V-3

proportional directional valve (requires amplifier card)

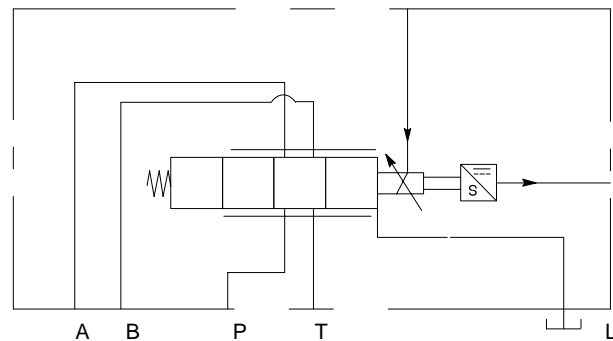
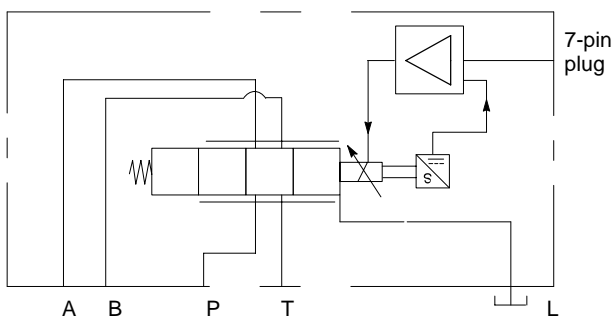

Operating data

Valves with integrated amplifier

KBSDG4V-3 Valves with integral amplifier: Data is typical: With fluid at 36 cSt (168 SUS) and 50°C (122°F).

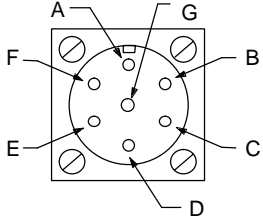
Power supply	24V DC (21V to 36V including 10% peak-to-peak max. ripple) max current 3A																		
Command signal Input impedance Common mode voltage to pin B	0 to +10V DC, or 0 to -10V DC, or -10 V to +10 V DC 47 kΩ 18V (max)																		
Valve enable signal for model code PH7 Enable Disable Input impedance	>8.5V (36V max) <6.5V 10 kΩ																		
7-pin plug connector  View of pins of fixed half.	<table border="1"> <thead> <tr> <th>Pin</th> <th>Description</th> </tr> </thead> <tbody> <tr> <td>A</td> <td>Power supply positive (+)</td> </tr> <tr> <td>B</td> <td>Power 0V</td> </tr> <tr> <td>C</td> <td>Command/Monitor 0V (PE7 & PC7)</td> </tr> <tr> <td>C</td> <td>Valve enable (PH7 & PR7)</td> </tr> <tr> <td>D</td> <td>Command signal (+)—non-inverting input</td> </tr> <tr> <td>E</td> <td>Command signal (—)—inverting input</td> </tr> <tr> <td>F</td> <td>Monitor input</td> </tr> <tr> <td>G</td> <td>Protective ground</td> </tr> </tbody> </table>	Pin	Description	A	Power supply positive (+)	B	Power 0V	C	Command/Monitor 0V (PE7 & PC7)	C	Valve enable (PH7 & PR7)	D	Command signal (+)—non-inverting input	E	Command signal (—)—inverting input	F	Monitor input	G	Protective ground
Pin	Description																		
A	Power supply positive (+)																		
B	Power 0V																		
C	Command/Monitor 0V (PE7 & PC7)																		
C	Valve enable (PH7 & PR7)																		
D	Command signal (+)—non-inverting input																		
E	Command signal (—)—inverting input																		
F	Monitor input																		
G	Protective ground																		
Electromagnetic compatibility (EMC): Emission (10 V/m) Immunity (10 V/m)	EN 50081-2 EN 50082-2																		
Zero adjustment	± 18% mechanical adjustment accessible under plug in LVDT																		
Monitor point signal Output impedance	± 10 V DC for full spool stroke 10kΩ																		
Power stage PWM frequency	10 kHz nominal																		
Reproducibility, valve-to-valve (at factory settings): Flow gain at 100% command signal	≤ 5%																		
Protection: Electrical Mechanical	Reverse polarity protected IEC 144, Class IP67																		
Relative humidity	85 to 95% at 20 to 70°C (68 to 158°F)																		
Ambient air temperature range for full performance Oil temperature range for full performance	0° C to 70° C (32° F to 158° F) 0° C to 70° C (32° F to 158° F)																		
Minimum temperature at which valves will work at reduced performance	-20° C (-4° F)																		
Storage temperature range	-25° C to +85° C (-13° F to +185° F)																		
Supporting products: Auxiliary electronic modules (DIN-rail mounting): EHA-CON-201-A2* signal converter EHD-DSG-201-A-1* command signal generator EHA-RMP-201-A-2* ramp generator EHA-PID-201-A-2* PID controller EHA-PSU-201-A-10 power supply	See catalog GB 2410A See catalog GB 2470 See catalog GB 2410A See catalog GB 2427 See catalog GB 2410A																		
KSDG4V-3 Valves without integral amplifier (requires a Eurocard amplifier, refer to Supporting Products)																			
Standing current at null	1,7 A																		
Max current, at 50° C (122° F) ambient	3,2 A																		
Coil resistance, at 20° C (68° F)	1,87Ω																		
Coil inductance, at 1000 Hz & 150 mV	7.2 mH																		

Operating data

Valves w/o integrated amplifier

KSDG4V-3 Valves without integral amplifier(continued)

Max solenoid power	30W
LVDT supply voltage	+15V DC
LVDT output signal	4 to 20 mA for spool stroke of 2,1 mm
Electromagnetic compatibility (EMC)	
Emission (10V/m)	EN 50081-2
Immunity (10V/m)	EN 50082-2
Base amplifier	EEA-PAM-553-A-3* Power requirements: 20 to 40V DC at 40W
Mechanical protection	IEC 144, Class IP65
Maximum allowable ambient air temperature	60° C (140° F)
Maximum allowable oil temperature	60° C (140° F)

KSDG4V-3 and KBSD/TG4V-3 Valves (all valves)

Relative duty factor	Continuous rating (ED = 100%)
Hysteresis	< 0.5%
Step response: Step size (% of max spool stroke): 0 to 100% or 100 to 0% 10 to 90% or 90 to 10% 25 to 75% or 75 to 25% +90 to -90%	Time to reach 90% of required step: 10 ms 8 ms 6 ms 12 ms)
Mass:	
KSDG4V-3	2,09 kg (4.6 lb) approx.
KBSDG4V-3	2,49 kg (5.5 lb) approx.

Pressures and Flow Rates Maximum pressures, bar (psi)

Port L condition	Ports P, A, B	T	L
Normally blocked by mounting surface	350 (5000)	50 (720)	50 (720)
Drained directly to tank	350 (5000)	210 (3000)	10 (145)

Performance Curves

Flow Gain

Flow from port P-A-B-T or P-B-A-T at
70 bar (1000 psi) total valve 
(35 bar (500 psi) per metering edge)

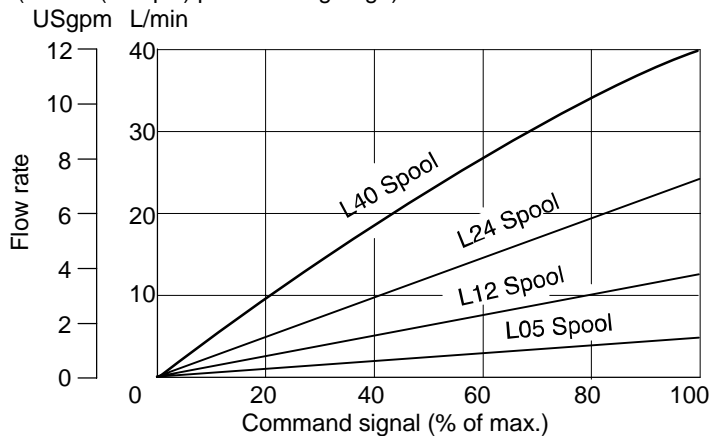

Pressure Gain

Δp between ports
A and B or B and
A, as % of port P
pressure

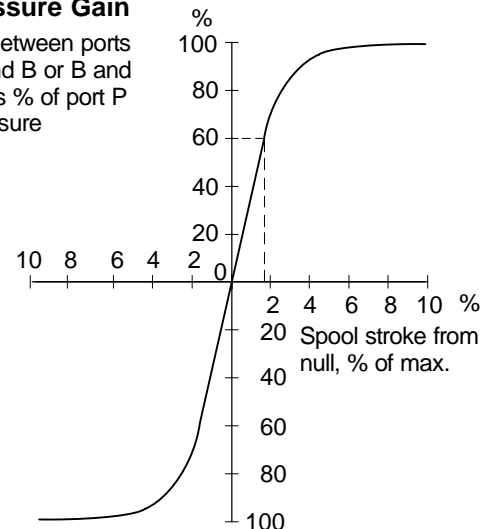

Performance Curves

Power Capacity Envelopes

K(B)SDG4V-3-9*L-05 Valves

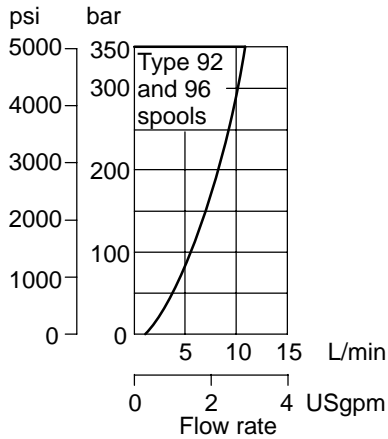

K(B)SDG4V-3-9*L-12 Valves

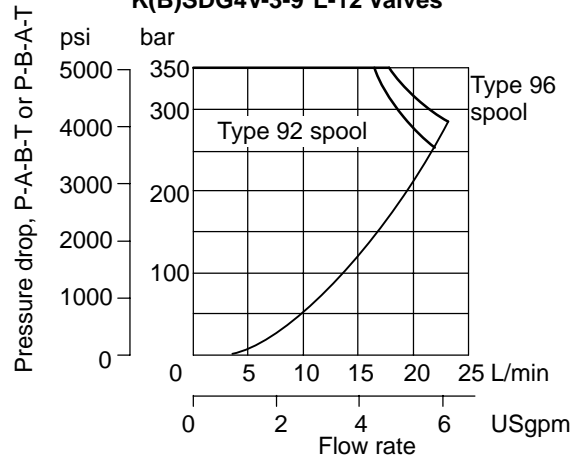

K(B)SDG4V-3-9*L-24 Valves

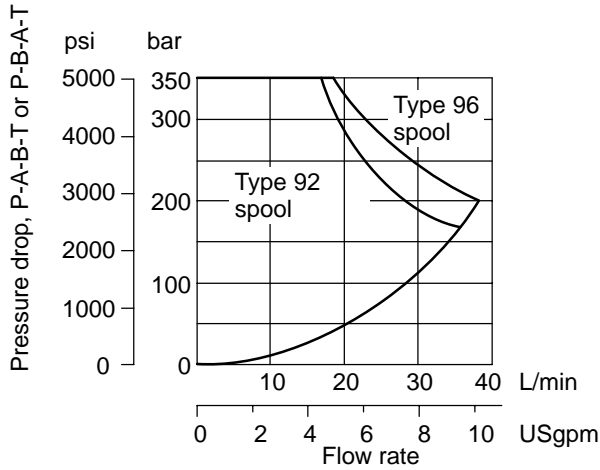

K(B)SDG4V-3-9*L-40 Valves

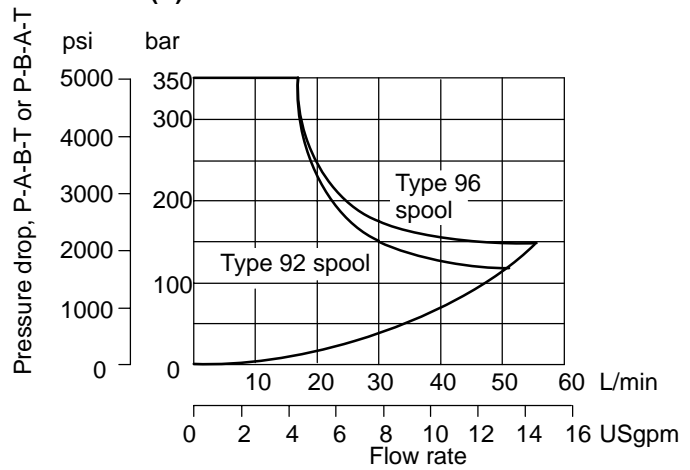

Frequency Response

Typical for amplitudes of $\pm 5\%$, $\pm 25\%$
with zero offset. Δp (P to T)=70 bar (1000 psi)

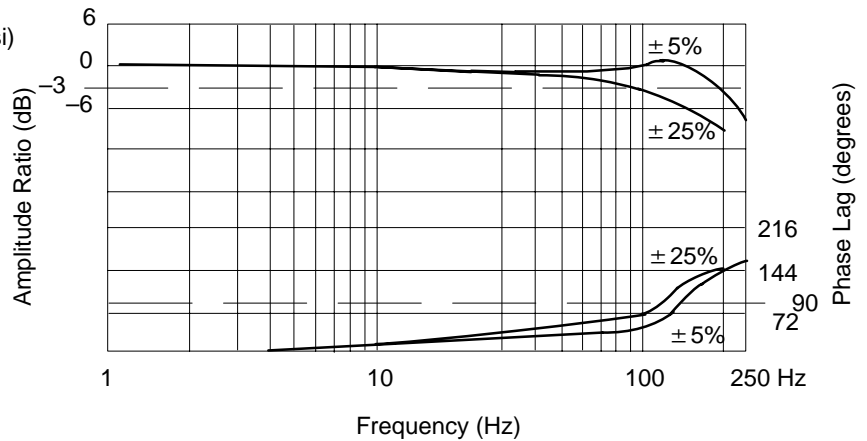

Installation Dimensions

KSDG4V-3

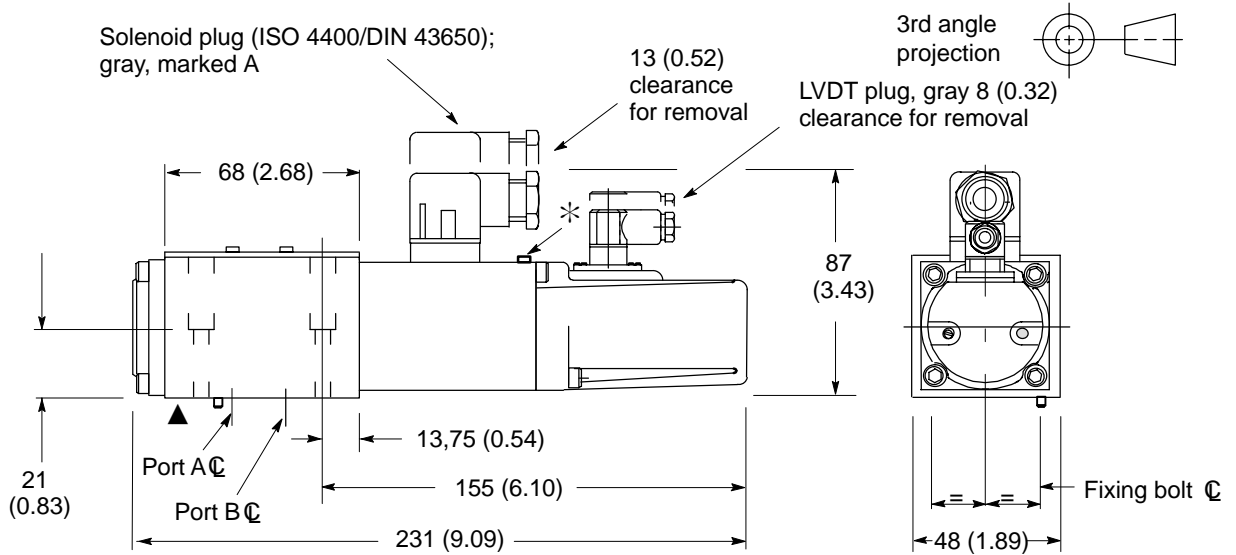

KBSDG4V-3

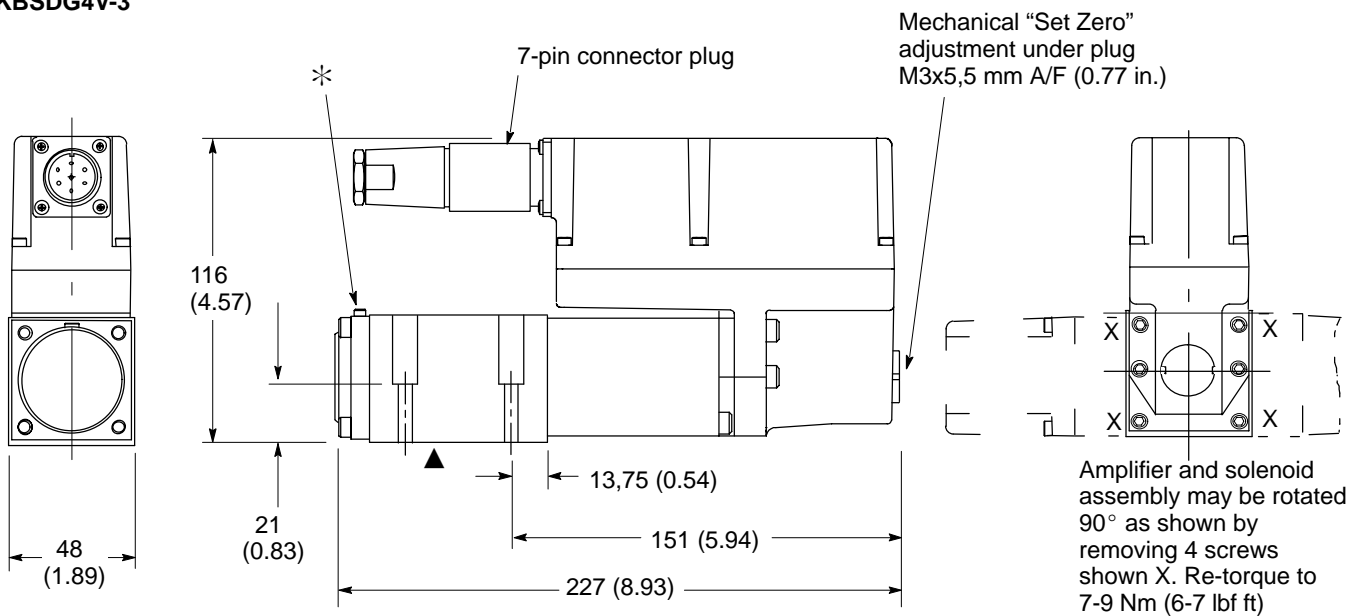

▲ Mounting surface seals supplied. For mounting surface dimensions and subplate options see page 9.

*Note: Bleed screw locations Air bleed, Socket Head Cap Screw. Torque to 2,5-3,0 Nm (2.0-2.5 lbf ft)

Warning
Valves with integral amplifiers are supplied with or without the metal 7-pin plug. The Vickers plug, part no. 934939, must be correctly fitted to ensure that the EMC rating and IP67 rating are achieved. The plug retaining nut must be tightened with a torque of 2-2,5 Nm (1.5-2.0 lbf ft) to effect a proper seal

Subplates and Mounting Surfaces

General Description

If a subplate is not used, a machined pad must be provided for valve mounting. Pad must be flat within 0,0127 mm (.0005 inch) and smooth within 1,6 µm (63 microinch). Mounting bolts, when provided by customer, should be ISO 898 class 12.9 or better.

Dimensional Tolerances

Dimensional tolerance on interface drawings is $\pm 0,2$ mm (± 0.008 ") except where otherwise stated. ISO 4401 specifies inch conversion to ± 0.01 " .

Conversion from Metric

ISO 4401 gives dimensions in mm. Inch conversions are accurate to 0.01" unless otherwise stated.

Mounting Bolt Tappings

ISO 4401 gives metric thread tappings. Alternate UNC tappings are Vickers recommendations that allow these plates and associated valves to be used up to their maximum pressures, when using Vickers recommended bolt kits, or bolts of an equivalent strength. It is recommended that Customer's own manifold blocks for UNC bolts should be tapped to the minimum depths given in the footnotes.

Subplates

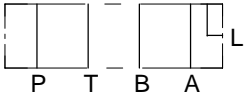
Description and Mass kg (lb)	Functional Symbol	Model Code	Max. Pressure
Single-station subplate; rear ports P, T, A, B; side port L Cast iron 1,3 (2.9)		KDGM-3-1*-R▲ KDGM-3-676803-1* (SAE/UNF ports)	250 bar (3600 psi)

* Design number subject to change. No change of installation dimensions for design numbers 10 to 19 or 21 to 29 inclusive.

▲ "S" suffix = SAE/UNC ports and/or UNC fixing bolt tappings and/or orifice plugs as appropriate.

"R" or "B" = ISO 228 (BSPF) ports and/or metric fixing bolt tappings and/or orifice plugs as appropriate.

Installation Dimensions

Single-Station Subplates, Rear and Side Tapped Ports

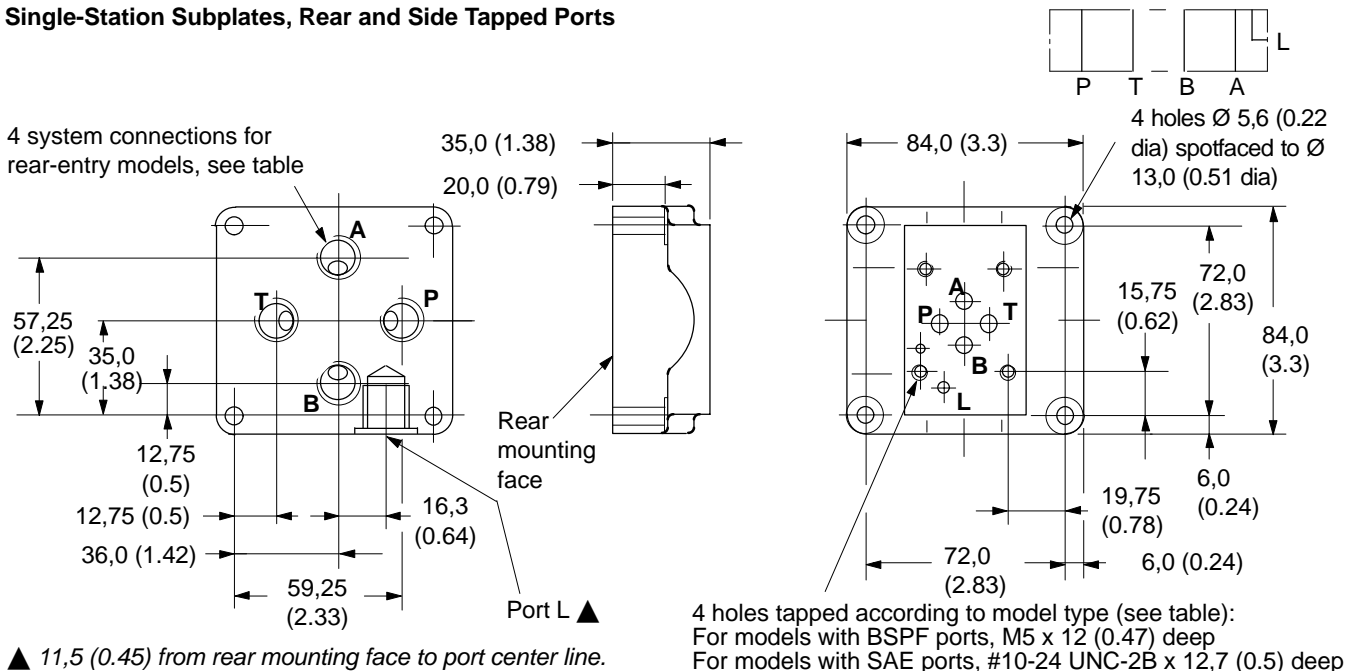

Port Threads

Model	Ports P, T, A, B, at rear or side	Port L
BSPF ports/M5 mounting bolts: KDGM-3-1*-R	Rear $G^{3/8}$ " ($3/8$ " BSPF) x 12,0 (0.47) deep	$G^{1/8}$ " ($1/8$ " BSPF) x 12,0 (0.47) deep
SAE ports/#10-24 UNC mounting bolts: KDGM-3-676803-1*	Rear $3/4$ "-16 UNF-2Bx14,3 (0.56) deep (SAE)	$7/16$ "-20 UNF-2B x 11,6 (0.46) deep (SAE)

Mounting Surface Interface

Mounting Surfaces to ISO 401 (Size 03)

This interface conforms to:
 ISO 4401-03-02-0-94
 plus location pin hole
 ANSI/B93.7M (and NFPA) size 03
 CETOP R35H4.2-4-03, plus location
 pin hole
 DIN 24340 Form A6 plus location
 pin hole

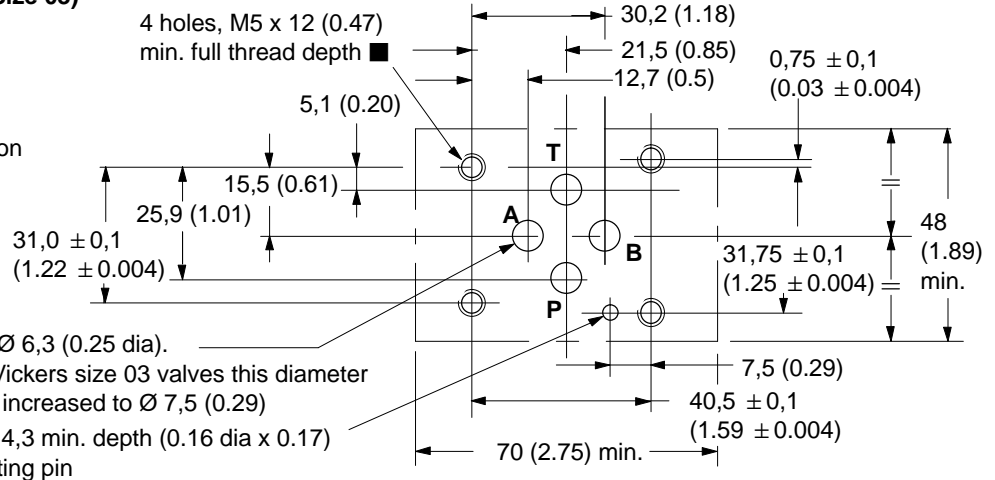

■ #10-24 UNC-2B optional.

Interface with Additional Drain Port

The interface conforms to Vickers
 standard, plus hole "L"

Typically used for proportional and
 other valves requiring an additional
 drain port.

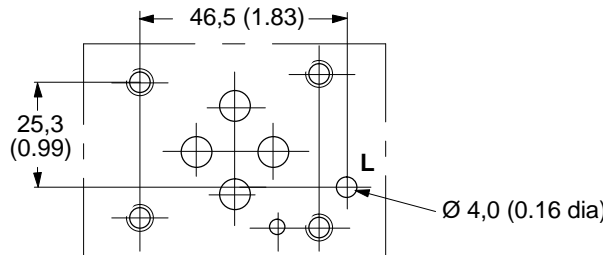

Electrical Information

Block Diagram KBSDG4V-3

Command Signals and Outputs

7-pin plug		Flow direction
Pin D	Pin E	
Positive	0V	P to A
0V	Negative	
$U_D - U_E = \text{Positive}$		P to B
Negative	0V	
0V	Positive	
$U_D - U_E = \text{Negative}$		

KBSDG4V-3 Wiring

Connections must be made via the 7-pin plug mounted on the amplifier. See page 11 of this leaflet and Installation Wiring Practices for Vickers Electronic Products, leaflet 2468. Recommended cable sizes are:

Power cables:

For 24V supply
 0,75 mm² (18 AWG) up to 20m (65 ft)
 1,00 mm² (16 AWG) up to 40m (130 ft)

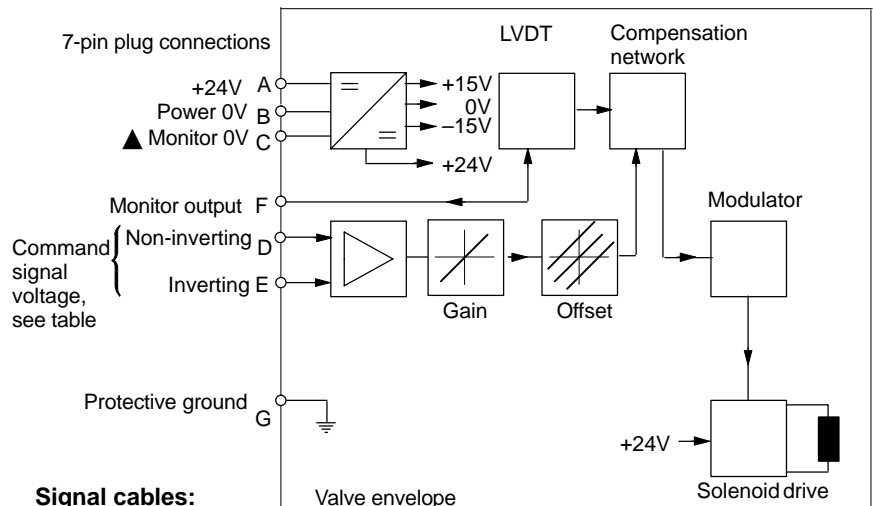

Signal cables:

0,50 mm² (20 AWG)

Screen (shield):

A suitable cable would have 7 cores, a separate screen for the signal wires and an overall screen.
 Cable outside diameter 8,0–10,5 mm (0.31–0.41 inches)
 See connection diagram on next page.

▲ Note: In valves with PH7 or PR7 type electrical connection, pin C is used for a valve enable signal.

KSDG4V-3 Wiring

Wiring details for these valves are contained in the appropriate Eurocard literature and the Installation Wiring Practices for Vickers Electronic Products leaflet 2468.



Warning

All power must be switched off before connecting/disconnecting any plugs.

Typical Connection Arrangements

Wiring Connections

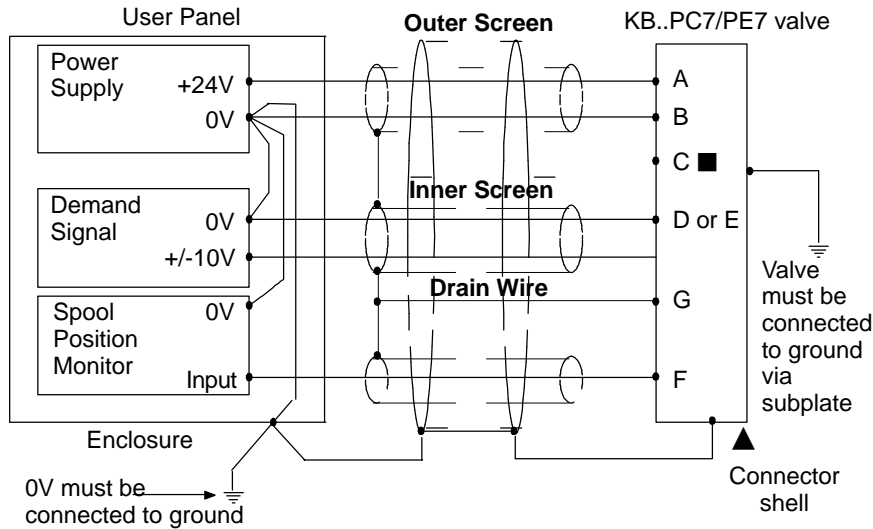

■ Spool position monitor voltage (pin F) will be referenced to the KB valve local ground. A "local ground" (pin C) is provided on PC7/PE7 versions for optional use by differential input customer supplied electronics.



WARNING

Do not ground pin C. If the local ground (pin C) is not used for differential monitor electronics, do not use. Read monitor pin F with respect to ground.

Wiring Connections for Valves with Enable Feature

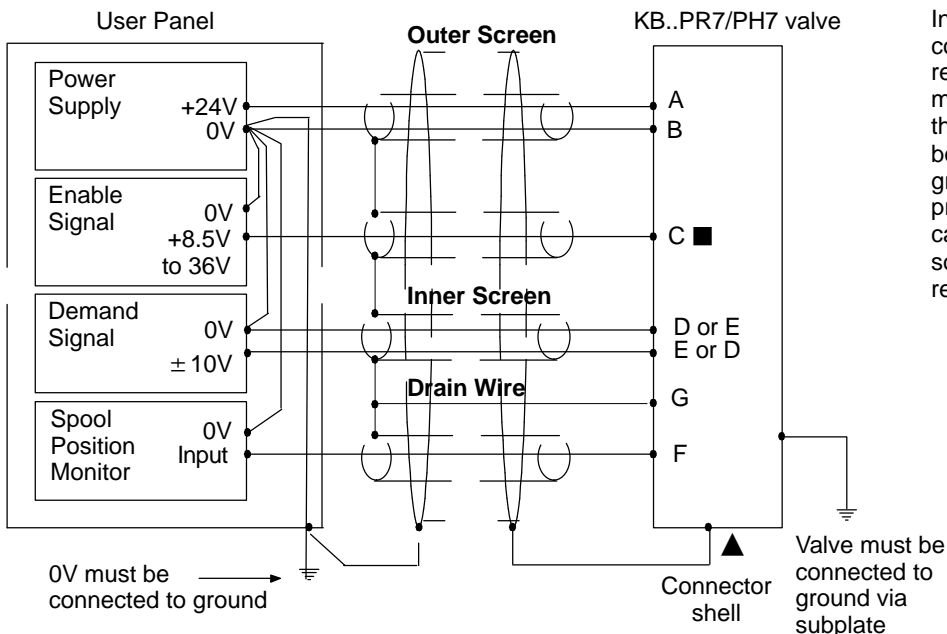

▲ Note:

In applications where the valve must conform to European RFI/EMC regulations, the outer screen (shield) must be connected to the outer shell of the 7 pin connector, and the valve body must be fastened to the earth ground. Proper earth grounding practices must be observed in this case, as any differences in command source and valve ground potentials will result in a screen (shield) ground loop.



Warning

Electromagnetic Compatibility (EMC)

It is necessary to ensure that the valve is wired up as above. For effective protection the user electrical cabinet, the valve subplate or manifold and the cable screens should be connected to efficient ground points. The metal 7 pin connector part no. 934939 should be used for the integral amplifier.

In all cases both valve and cable should be kept as far away as possible from any sources of electromagnetic radiation such as cables carrying heavy current, relays and certain kinds of portable radio transmitters, etc. Difficult environments could mean that extra screening may be necessary to avoid the interference.

It is important to connect the 0V lines as shown above. The multi-core cable should have at least two screens to separate the demand signal and monitor output from the power lines.

The enable line to pin C should be outside the screen which contains the demand signal cables.

Application Data

Fluid Cleanliness

Proper fluid condition is essential for long and satisfactory life of hydraulic components and systems. Hydraulic fluid must have the correct balance of cleanliness, materials and additives for protection against wear of components, elevated viscosity and inclusion of air.

Recommendations on contamination control methods and the selection of products to control fluid condition are included in Vickers publication 9132 or 561, "Vickers Guide to Systemic Contamination Control". The book also includes information on the Vickers concept of "ProActive Maintenance". The following recommendations are based on ISO cleanliness levels at 2 μ m and 15 μ m.

For products in this catalog the recommended levels are:
0 to 70 bar (1000 psi) 18/16/13
70 + bar (1000 + psi) 17/15/12

Vickers products, as any components, will operate with apparent satisfaction in fluids with higher cleanliness codes than those described. Other manufacturers will often recommend levels above those specified.

Experience has shown, however, that life of any hydraulic components is shortened in fluids with higher cleanliness codes than those listed above. These codes have been proven to provide a long trouble-free service life for the products shown, regardless of the manufacturer.

Hydraulic Fluids

Materials and seals used in these valves are compatible with antiwear hydraulic oils, and non-alkyl-based phosphate esters. The extreme operating viscosity range is 500 to 13 cSt (2270 to 70 SUS) but the recommended running range is 54 to 13 cSt (245 to 70 SUS).

Installation

The proportional valves in this catalog can be mounted in any attitude, but it may be necessary in certain demanding applications, to ensure that the solenoids are kept full of hydraulic fluid. Good installation practice dictates that the tank port and any drain port are piped so as to keep the valves full of fluid once the system start-up has been completed.

Mounting Bolt Kits

For K(B)SDG4V-3

BK02-156493M(metric)

BK590716 (inch)

If not using Vickers recommended bolt kits, bolts used should be to ISO 898, 12.9 or better.

Seal Kits

KSDG4V-3-1* 565108

KBSDG4V-3-1* 02-332693

Plugs

KBSDG4V

7-pin plug (metal) 934939

7-pin plug (plastic) 694534

(metal plug must be used for full EMC protection)

Plugs

KSDG4V

Solenoid (grey) 710776

LVDT (grey) 458939

NOTE: An alternative metal connector which gives EMC protection but not IP67 rating is available from ITT-Cannon, part number CA06-COM-E-14S-A7-S. For IP rating consult the manufacturer.

Extension Cable

Extension Cable: Adapter for extending 7 core cable when changing from KA to KB valve and existing wiring is not long enough. Consists of a 7 pin plug, a 7 pin socket and a length of cable, fully assembled for ease of use

Extension Cable 944450

Service Information

The products from this range are preset at the factory for optimum performance; disassembling critical items would destroy these settings. It is therefore recommended that should any mechanical or electronic repair be necessary they should be returned to the nearest Vickers repair center. The products will be refurbished as necessary and retested to specification before return.

Field repair is restricted to the replacement of the seals.

Note: The feedback/solenoid assembly installed in this valve should not be disassembled.



Vickers Systems Division
Aeroquip-Vickers, Ltd
P.O. Box 4
46 New Lane,
Havant PO9 2NB
UK

Aeroquip-Vickers do Brazil S.A.
CEP 07250-270
Av. Julia Gaioli, 450
Bonsucesso-Guarulhos
Sao Paulo 07
Brazil

Vickers Asia Pacific Ltd
Tennozu Parkside Building
2-5-8 Higashi Shinagawa
Shinagawa-ku
Tokyo 140
Japan

Vickers, Incorporated
5445 Corporate Drive
P.O. Box 302
Troy, Michigan
48007-0302
USA